

## VPL-CX235 Projector

XGA resolution installation projector with  
4100 lumens brightness



The VPL-CX235 is designed to deliver a low total cost of ownership and includes easy to operate, environmentally conscious features without compromising on superior quality and reliability.

The projector offers a 4100 lumen brightness and 1.66 - 2.41:1 throw ratio for new or replacement business in most large classrooms and large meeting rooms.

Furthermore, in common with all Sony projectors, the VPL-CX235 features the Sony BrightEra 3LCD inorganic panel technology that delivers higher picture quality, substantially brighter images, higher efficiency, better contrast, consistent colour stability and longer durability and usability.

The VPL-CX235 also features 3 brightness modes to suit each individual user's needs. The low brightness mode generates lower operating costs by reducing power consumption and extending the lamp lifetime to approximately 5000 hours. This projector also has a contrast ratio of 3100:1, video inputs, HDMI and RJ45 or RS232C connectors for control.

### Maximum 4100 lumens brightness with High, Standard and Low modes

The VPL-CX235 features three brightness modes for different uses – High for naturally white presentations in bright rooms (4100 lumens), Standard for everyday use (3100 lumens) and Low for video in darkened rooms (2200 lumens).

### Lens Shift Function

The projector is equipped with horizontal and vertical lens shift functions for greater installation flexibility. Using this function, the position of the projected image can be moved vertically up and down by 5.0% and horizontally from -4.0% through to +4.0%.

### 1.66 - 2.41:1 Throw Ratio

The VPL-CX235 offers a 1.66 - 2.41:1 throw ratio that can accommodate most large classrooms or large meeting rooms current replacement installation requirements.

### ECO Mode Key

Users can easily select power-saving ECO Modes. The most energy-efficient mode is accessible through a single button-push, with further adjustments available through an easily understood menu system.

### Filter replaced at the same time as Lamp

The filter only needs to be changed when a new lamp is fitted, potentially halving disruption due to maintenance.

## Key Features

### ECO Lamp Dimming

This projector (if this function is selected) can reduce power consumption and brightness by 10 -15%. After a user pre-set time, the brightness and power consumption will reduce to 30% power usage, with instant 100% brightness returning as soon as a new signal input is detected.

### ECO Picture Mute - (Instant Off/Instant On)

The new ECO Picture Mute feature reduces power consumption down to 30%, saving cost and lamp hours. This feature can be used in the classroom as instant off/instant on in-between class changes or in the corporate market as a tool to redirect attention away from the screen. There is no need to power completely off and turn back on which is time consuming.

### 5000 Hours Lamp Life

A new driving scheme reduces gap expansion that minimises brightness gradation. A new cooling system allows uniformity in the temperature of the glass bulb which prevents the glass from clouding.

## Other Features

### Vertical Keystone Adjustment

The projector can correct keystone distortion by V: +/- 30% H: +/- 20% for perfect installation adjustment. (Note that since this is an electronic correction, it will reduce the picture quality slightly.)

### Image Warping

The image warping feature allows an 8 point (4 corners and 4 sides) image adjustment for convex or concave projected surfaces. Making adjustments is easy with the remote control and the on-screen operating menu.

### Digital Zoom

With Digital Zoom, users can enlarge a selected area of a computer-source image on the screen up to four times.

### Multiple Picture Modes

The VPL-CX235 has six picture modes (Dynamic, Standard, Game, Living, Cinema and Presentation) that can be selected to suit the nature of the source material.

### 3LCD BrightEra Technology

The Sony 0.63 inch BrightEra inorganic TFT 3LCD panels deliver improved panel light resistance, higher resolution, high brightness and increased panel reliability.

### Smart APA (Auto Pixel Alignment)

When a computer is used as a picture source, APA automatically optimises Phase, Pitch and Shift values. These can also be adjusted manually.

### Auto Input Search

Auto Input Search detects which input has an incoming signal and automatically switches to it. This makes it easier for users to set up the projector prior to making a presentation.

### Picture Muting

If the picture needs to be turned off, all it takes is a single button-press on the remote control. This will mute audio at the same time. There is also a separate "mute audio" button for audio-only muting.

### Audio Switcher Facility

To avoid the need for a separate audio switcher, the projector can be used to select between two audio sources, routing them via a variable audio output to the room amplification system.

### Picture Freeze Function

Picture Freeze is useful during presentations where users need to look at other material on their PC's screen without the viewing audience being aware. Freeze the current image and users can use their PC independently of the display from the projector.

### Off and Go

At the end of a presentation, users can turn off the power supply to the projector immediately, instead of going through a 'power down' cycle.

### Direct Power On/Off

With this function, there is no need to go through 'Standby' mode when powering up the projector. The projector can be set to activate as soon as power is supplied.

### Built-in Security Measures

The VPL-CX235 has a package of security measures, including password protection and physical anti-theft anchor points.

## PrimeSupport

All Sony Professional's business projectors sold into the EU, Norway and Switzerland come supplied with a 3 year PrimeSupport pack. This offers unique services and benefits over and above standard warranty:-

### 3 Years Cover

Freephone telephone helpdesk support (00800 7898 7898) in 5 languages. Collection, repair and return anywhere in EU, Norway and Switzerland.

In addition, optional PrimeSupport Plus packs can be purchased which can further enhance the 3 year support to give extra peace of mind:-

- A 2 year extension of the standard 3 year PrimeSupport to give long-term assurance of expert support, technical assistance and repairs for 5 years from purchase date.
- Provision of a loan unit for 3 or 5 years cover to ensure minimal impact to the customer's business in case of product failure.

- Cover for a lamp failure throughout the 3 year PrimeSupport term for customers who don't want to have any unexpected running costs.



Dimensions

Front

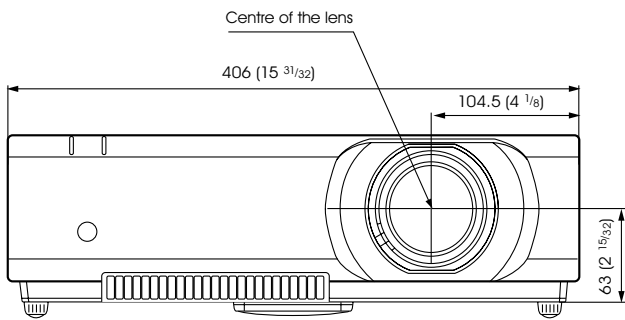

Side

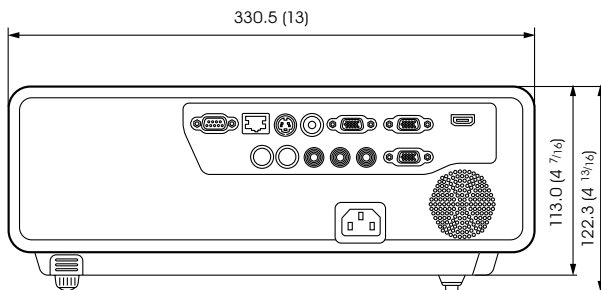

Bottom

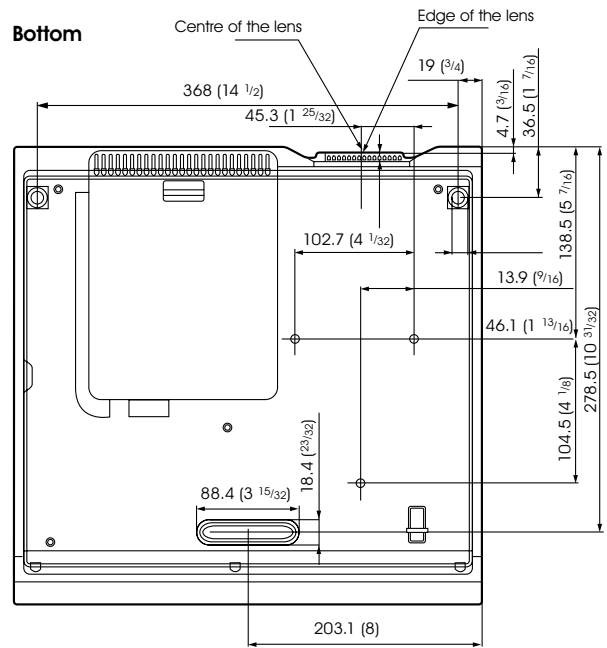

Unit: mm (inches)

Connector Panel



## Technical Specifications

Specifications		VPL-CX235
Display system		3 LCD system
Display device	Size of effective display area	0.63" (16.0 mm) x 3, BrightEra, Aspect ratio: 4:3
	Number of pixels	2,359,296 (1024 x 768 x 3) pixels
Projection lens	Zoom	x1.5
	Focus	Manual
	Lens Shift	Manual V: +/- 5% H: +/- 4%
Throw Ratio		1.66 - 2.41:1
Light source		High-pressure mercury lamp 245 W type
Recommended lamp replacement time*1		3000 H / 4000 H / 5000 H (Lamp mode: High / Standard / Low)
Filter cleaning cycle*1		Max. 5000 H / Same time as the lamp replacement is recommended
Screen size		40" to 300" (1.02 m to 7.69 m)
Light output (Lamp mode: High / Standard / Low)		4100 lm / 3100 lm / 2200 lm
Colour light output		4100 lm / 3100 lm / 2200 lm
Contrast ratio (full white / full black)*2		3100:1
Fan noise		30dB (low)
Speaker		10 W x 1 (monaural)
Displayable scanning frequency	Horizontal	19 kHz - 92 kHz
	Vertical	48 Hz - 92 Hz
Display resolution	Computer signal input	Maximum input signal resolution: UXGA 1600 x 1200*3 (resizing display), Panel display resolution: 1024 x 768 pixels
	Video signal input	NTSC3.58, PAL, SECAM, 480/60i, 576/50i, 480/60p, 576/50p, 720/60p, 720/50p, 1080/60i, 1080/50i
Colour system		Auto / NTSC3.58, PAL, SECAM, NTSC4.43, PAL-M, PAL-N, PAL60
Colour System Resolution (V & H) Keystone correction		720 TV Lines Vertical: Max. +/- 30 degrees Horizontal: Max. +/- 20% degrees
OSD language		20-languages (English, Dutch, French, Italian, German, Spanish, Portuguese, Turkish, Polish, Russian, Swedish, Norwegian, Japanese, Simplified Chinese, Traditional Chinese, Korean, Thai, Vietnamese, Arabic, Persian)
Computer and video signal input/output	INPUT A	RGB / Y PB PR input connector: Mini D-sub 15-pin (female), Audio input connector: Stereo mini jack
	INPUT B	RGB input connector: Mini D-sub 15-pin (female), Audio input connector: Stereo mini jack
	INPUT C	HDMI 19-pin, HDCP support, Audio input: HDMI audio support
	S VIDEO IN	S video input connector: Mini DIN 4-pin, Audio input connector: RCA (Shared with Video In)
	VIDEO IN	Video input connector: RCA, Audio input connector: RCA (Shared with S-Video)
	OUTPUT	Monitor output connector*4: Mini D-sub 15-pin (female), Audio output connector*5: Stereo mini jack (variable out)
Other signal input/output		RS-232C connector: D-sub 9-pin (female) LAN connector: RJ45, 10BASE-T/100BASE-TX

Specifications		VPL-CX235
Operating temperature (Operating humidity)		0°C to 40°C / 32°F to 104°F (35% to 85% (no condensation))
Storage temperature (Storage humidity)		-10°C to 60°C / -4°F to 140°F (10% to 90%)
Power requirements		AC 100 V to 240 V, 1.4A to 3.6 A 50 Hz / 60 Hz
Power consumption	AC 100 V to 120 V	340 W / 280W / 240W (Lamp mode: High / Standard / Low)
	AC 220 V to 240 V	320 W / 265W / 225W (Lamp mode: High / Standard / Low)
Standby mode power consumption	AC 100 V to 120 V	3W / < 0.5 W (Standby mode: Standard / Low)
	AC 220 V to 240 V	3W / < 0.5 W (Standby mode: Standard / Low)
Heat dissipation	AC 100 V to 120 V	1,195BTU
	AC 220 V to 240 V	1,126BTU
Standard outside dimensions		W 406 x H 122.3 x D 330.5 mm / W 15 31/32 x H 4 13/16 x D 13 in W 406 x H 113 x D 330.5 mm / W 15 31/32 x H 4 4/16 x D 13 in (without protrusion)
Mass		5.5kg / 12lb 2oz
Supplied accessories		RM-PJ7 Remote Commander RM-PJ7, (1) CR2025 Lithium Battery, (1) AC Power Cord Mini D-sub 15-pin cable (1), Lens Cap (1), Operating Instructions (1) EU Battery Info, Warranty Documentation Quick Reference Manual (1)
Optional accessory		LMP-C240 Projector Lamp

\*1: The figures are expected maintenance time and not guaranteed. They will depend on the environment or how the projector is used.  
\*2: The value is average.

\*3: Available for VESA reduced blanking signal.  
\*4: Not available in standby.  
\*5: Works as audio switcher function. From current channel only. Not available in standby.

### Optional Accessory



**LMP-C240**  
Projector Lamp (for replacement)

© 2011 Sony Corporation. All rights reserved. Reproduction in whole or in part without permission is prohibited. Features and specifications are subject to change without notice. All non-metric weights and measurements are approximate. Sony and make.believe are trademarks of Sony Corporation. All other trademarks are the property of their respective owners.

Distributed by

#### About Sony Professional

Sony Professional is the leading supplier of AV/IT solutions to businesses across a wide variety of sectors including, **Media and Broadcast, Video Security and Retail, Transport & Large Venue markets**. It delivers products, systems and applications to enable the creation, manipulation and distribution of digital audio-visual content that add value to businesses and their customers. With over 25 years' experience in delivering innovative market-leading products, Sony Professional is ideally placed to deliver exceptional quality and value to its customers. Sony's Professional Services division, its systems integration arm, offers its customers access to the expertise and local knowledge of skilled professionals across Europe. Collaborating with a network of established technology partners, Sony Professional delivers end to end solutions that address the customer's needs, integrating software and systems to achieve each organisations' individual business goals. For more information please visit [www.pro.sony.eu](http://www.pro.sony.eu)

HCT\_VPL-CX235\_11004\_UK\_02/2012

**SONY**  
make.believe